

## 中压电容器用串联电抗

### AST-UL-600/10-6%

#### 四、性能参数

- 1、耐温等级达到 F 级（155℃）；正常运行时，电抗器的铁芯温升不大于 85K，线圈温升不大于 95K。
- 2、电抗器能在 1.35 倍额定电流下长期运行。
- 3、电抗器的噪声不大于国家标准。
- 4、电抗器耐压水平符合 JB5346-1998《串联电抗器》的规定。
- 5、电抗率：1%~14%。
- 6、执行标准：GB10229，JB5346，IEC60076-6。

#### 五、接线方式

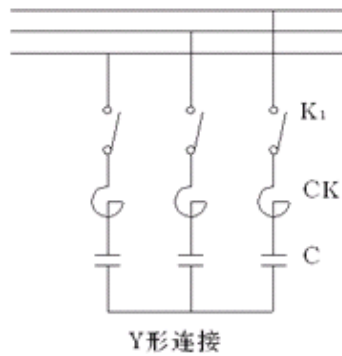

#### 六、图片



## 七、技术参数及外形尺寸

AST-UL 型, 6kV 系统, 三相, XL/XC=6%, 匹配电容器额定电压: 6.6kV

电抗器型号	匹配电容器规格 (kvar)	电抗器容量 (kvar)	额定电感量 (mH)	外形尺寸 L*W*H (mm)	安装尺寸 (mm)
AST-UL-6/6-6	100	6	3*83.193	600*400*680	400*300, 4-Φ12
AST-UL-9/6-6	150	9	3*55.462	630*400*710	400*300, 4-Φ12
AST-UL-12/6-6	200	12	3*41.597	630*400*770	400*300, 4-Φ14
AST-UL-15/10-6	250	15	3*33.277	660*400*740	450*300, 4-Φ14
AST-UL-18/6-6	300	18	3*27.731	660*400*760	450*300, 4-Φ14
AST-UL-24/6-6	400	24	3*20.798	690*450*810	450*350, 4-Φ14
AST-UL-27/6-6	450	27	3*18.487	690*450*840	450*350, 4-Φ14
AST-UL-30/6-6	500	30	3*16.639	720*450*830	500*350, 4-Φ14
AST-UL-36/6-6	600	36	3*13.866	720*450*870	500*350, 4-Φ14
AST-UL-45/6-6	750	45	3*11.092	780*500*900	500*400, 4-Φ14
AST-UL-54/6-6	900	54	3*9.243	810*500*930	550*400, 4-Φ14
AST-UL-60/6-6	1000	60	3*8.319	840*500*970	550*400, 4-Φ14
AST-UL-72/6-6	1200	72	3*6.933	870*500*1060	600*400, 4-Φ14
AST-UL-90/6-6	1500	90	3*5.546	900*500*1110	600*400, 4-Φ14
AST-UL-120/6-6	2000	120	3*4.159	990*550*1120	600*450, 4-Φ16
AST-UL-144/6-6	2400	144	3*3.466	1020*550*1200	600*450, 4-Φ16
AST-UL-180/6-6	3000	180	3*2.773	1050*550*1310	650*450, 4-Φ16
AST-UL-216/6-6	3600	216	3*2.311	1200*600*1380	750*500, 4-Φ16
AST-UL-240/6-6	4000	240	3*2.080	1200*600*1480	750*500, 4-Φ16
AST-UL-252/6-6	4200	252	3*1.981	1200*600*1490	750*500, 4-Φ16
AST-UL-288/6-6	4800	288	3*1.733	1230*600*1610	750*500, 4-Φ16
AST-UL-300/6-6	5000	300	3*1.664	1260*650*1620	800*550, 4-Φ16

AST-UL 型, 6kV 系统, 三相, XL/XC=12%, 匹配电容器额定电压: 7.2kV

电抗器型号	匹配电容器规格 (kvar)	电抗器容量 (kvar)	额定电感量 (mH)	外形尺寸 L*W*H (mm)	安装尺寸 (mm)
AST-UL-12/6-12	100	12	3*198.01	660*400*710	450*300, 4-Φ14
AST-UL-18/6-12	150	18	3*132.010	660*400*790	450*300, 4-Φ14
AST-UL-24/6-12	200	24	3*99.007	690*450*810	450*350, 4-Φ14
AST-UL-36/6-12	300	36	3*66.004	720*450*860	500*350, 4-Φ14
AST-UL-54/6-12	450	54	3*44.003	780*500*930	500*400, 4-Φ14
AST-UL-60/6-12	500	60	3*39.603	810*500*940	550*400, 4-Φ14
AST-UL-72/6-12	600	72	3*33.002	840*500*1030	550*400, 4-Φ14
AST-UL-90/6-12	750	90	3*26.402	870*500*1120	600*400, 4-Φ14
AST-UL-108/6-12	900	108	3*22.002	990*500*1160	600*400, 4-Φ16

AST-UL-120/6-12	1000	120	3*19.801	1020*550*1220	600*450, 4-Φ16
AST-UL-144/6-12	1200	144	3*16.501	1050*550*1330	650*450, 4-Φ16
AST-UL-180/6-12	1500	180	3*13.201	1200*600*1250	750*500, 4-Φ16
AST-UL-216/6-12	1800	216	3*11.001	1230*600*1350	750*500, 4-Φ16
AST-UL-252/6-12	2100	252	3*9.430	1260*600*1410	800*500, 4-Φ16
AST-UL-288/6-12	2400	288	3*8.251	1260*600*1520	800*500, 4-Φ16
AST-UL-324/6-12	2700	324	3*7.333	1290*650*1590	800*550, 4-Φ18
AST-UL-360/6-12	3000	360	3*6.600	1320*650*1610	800*550, 4-Φ18
AST-UL-396/6-12	3300	396	3*6.000	1350*650*1620	850*550, 4-Φ18
AST-UL-432/6-12	3600	432	3*5.500	1410*650*1610	900*550, 4-Φ18
AST-UL-480/6-12	4000	480	3*4.950	1440*650*1610	900*550, 4-Φ18
AST-UL-504/6-12	4200	504	3*4.714	1470*650*1700	900*550, 4-Φ18
AST-UL-576/6-12	4800	576	3*4.125	1470*700*1730	900*600, 4-Φ18
AST-UL-600/6-12	5000	600	3*3.960	1470*700*1760	900*600, 4-Φ18

AST-UL 型, 10kV 系统, 三相, XL/XC=6%, 匹配电容器额定电压: 11kV

电抗器型号	匹配电容器规格 (kvar)	电抗器容量 (kvar)	额定电感量 (mH)	外形尺寸 L*W*H (mm)	安装尺寸 (mm)
AST-UL-6/10-6	100	6	3*233.223	680*400*740	450*300, 4-Φ12
AST-UL-9/10-6	150	9	3*153.514	680*400*800	450*300, 4-Φ12
AST-UL-12/10-6	200	12	3*115.501	710*450*870	500*350, 4-Φ14
AST-UL-18/10-6	300	18	3*77.246	740*450*840	500*350, 4-Φ14
AST-UL-27/10-6	450	27	3*51.388	770*450*900	500*350, 4-Φ14
AST-UL-30/10-6	500	30	3*46.289	770*450*890	500*350, 4-Φ14
AST-UL-36/10-6	600	36	3*38.500	800*500*880	550*400, 4-Φ14
AST-UL-45/10-6	750	45	3*30.781	830*550*910	550*450, 4-Φ14
AST-UL-54/10-6	900	54	3*25.694	860*550*930	550*450, 4-Φ14
AST-UL-60/10-6	1000	60	3*23.100	860*550*950	600*450, 4-Φ14
AST-UL-72/10-6	1200	72	3*19.250	890*550*1010	600*450, 4-Φ14
AST-UL-90/10-6	1500	90	3*15.410	930*550*1030	600*450, 4-Φ14
AST-UL-108/10-6	1800	108	3*12.833	1070*600*1090	650*500, 4-Φ16
AST-UL-120/10-6	2000	120	3*11.555	1090*600*1110	650*500, 4-Φ16
AST-UL-144/10-6	2400	144	3*9.629	1090*600*1190	650*500, 4-Φ16
AST-UL-180/10-6	3000	180	3*7.703	1090*600*1260	650*500, 4-Φ16
AST-UL-216/10-6	3600	216	3*6.419	1120*600*1340	650*500, 4-Φ16
AST-UL-240/10-6	4000	240	3*5.777	1150*600*1360	700*500, 4-Φ16
AST-UL-252/10-6	4200	252	3*5.502	1150*600*1400	700*500, 4-Φ16
AST-UL-288/10-6	4800	288	3*4.814	1180*650*1420	700*500, 4-Φ16
AST-UL-300/10-6	5000	300	3*4.622	1370*650*1350	850*550, 4-Φ16
AST-UL-324/10-6	5400	324	3*4.28	1370*650*1370	850*550, 4-Φ18

AST-UL-360/10-6	6000	360	3*3.852	1370*650*1400	850*550, 4-Φ18
AST-UL-432/10-6	7200	432	3*3.21	1430*650*1500	900*550, 4-Φ18
AST-UL-468/10-6	7800	468	3*2.963	1430*650*1600	900*550, 4-Φ18
AST-UL-480/10-6	8000	480	3*2.889	1430*650*1660	900*550, 4-Φ18
AST-UL-600/10-6	10000	600	3*2.311	1460*650*1700	900*550, 4-Φ18

AST-UL 型, 10kV 系统, 三相, XL/XC=12%, 匹配电容器额定电压: 12kV

电抗器型号	匹配电容器规格 (kvar)	电抗器容量 (kvar)	额定电感量 (mH)	外形尺寸 L*W*H (mm)	安装尺寸 (mm)
AST-UL-12/10-12	100	12	3*551.074	710*400*850	500*300, 4-Φ14
AST-UL-18/10-12	150	18	3*367.383	710*450*920	500*350, 4-Φ14
AST-UL-24/10-12	200	24	3*275.537	740*450*890	500*350, 4-Φ14
AST-UL-36/10-12	300	36	3*183.691	800*500*930	500*400, 4-Φ14
AST-UL-54/10-12	450	54	3*121.897	860*500*1000	600*400, 4-Φ14
AST-UL-60/10-12	500	60	3*110.008	890*500*990	600*400, 4-Φ14
AST-UL-72/10-12	600	72	3*91.673	920*500*1040	600*400, 4-Φ14
AST-UL-90/10-12	750	90	3*73.339	950*550*1130	650*450, 4-Φ14
AST-UL-108/10-12	900	108	3*61.116	1070*550*1240	650*450, 4-Φ14
AST-UL-120/10-12	1000	120	3*54.993	1070*550*1130	650*450, 4-Φ14
AST-UL-144/10-12	1200	144	3*45.843	1280*600*1290	800*500, 4-Φ16
AST-UL-180/10-12	1500	180	3*36.637	1310*600*1350	800*500, 4-Φ16
AST-UL-216/10-12	1800	216	3*30.545	1340*650*1440	800*550, 4-Φ16
AST-UL-252/10-12	2100	252	3*26.190	1370*650*1520	800*550, 4-Φ16
AST-UL-288/10-12	2400	288	3*22.902	1370*650*1610	800*550, 4-Φ16
AST-UL-324/10-12	2700	324	3*20.363	1400*650*1670	850*550, 4-Φ18
AST-UL-360/10-12	3000	360	3*18.331	1430*650*1710	900*550, 4-Φ18
AST-UL-396/10-12	3300	396	3*16.657	1430*650*1780	900*550, 4-Φ18
AST-UL-432/10-12	3600	432	3*15.272	1460*650*1810	900*550, 4-Φ18
AST-UL-480/10-12	4000	480	3*13.748	1490*700*1880	900*600, 4-Φ18
AST-UL-504/10-12	4200	504	3*13.088	1580*650*1550	1000*550, 4-Φ18
AST-UL-576/10-12	4800	576	3*11.456	1640*700*1560	1000*600, 4-Φ18
AST-UL-600/10-12	5000	600	3*11.001	1460*650*1690	900*550, 4-Φ18
AST-UL-648/10-12	5400	648	3*10.181	1490*650*1720	900*550, 4-Φ20
AST-UL-720/10-12	6000	720	3*9.167	1550*700*1660	950*600, 4-Φ20
AST-UL-864/10-12	7200	864	3*7.394	1580*700*1760	1000*600, 4-Φ20
AST-UL-936/10-12	7800	936	3*7.052	1580*700*1860	1000*600, 4-Φ20
AST-UL-960/10-12	8000	960	3*6.875	1580*700*1960	1000*600, 4-Φ20
AST-UL-1200/10-12	10000	1200	3*5.504	1730*750*2070	1100*650, 4-Φ20

AST-UL 型, 20kV 系统, 三相, XL/XC=6%, 匹配电容器额定电压: 22kV

电抗器型号	匹配电容器规格 (kvar)	电抗器容量 (kvar)	额定电感量 (mH)	外形尺寸 L*W*H (mm)	安装尺寸 (mm)
AST-UL-120/20-6	2000	120	3*46.219	1130*500*1460	800*400, 4-Φ16
AST-UL-144/20-6	2400	144	3*38.516	1160*550*1500	800*450, 4-Φ16
AST-UL-180/20-6	3000	180	3*30.812	1190*550*1590	800*450, 4-Φ16
AST-UL-240/20-6	4000	240	3*23.109	1400*600*1610	1000*500, 4-Φ16
AST-UL-270/20-6	4500	270	3*20.542	1430*600*1650	1000*500, 4-Φ16
AST-UL-300/20-6	5000	300	3*18.487	1460*650*1680	1050*550, 4-Φ16

AST-UL 型, 20kV 系统, 三相, XL/XC=12%, 匹配电容器电压: 24kV

电抗器型号	匹配电容器规格 (kvar)	电抗器容量 (kvar)	额定电感量 (mH)	外形尺寸 L*W*H (mm)	安装尺寸 (mm)
AST-UL-240/20-12	2000	240	3*110.01	1250*550*1740	850*450, 4-Φ16
AST-UL-288/20-12	2400	300	3*91.720	1310*600*1780	900*500, 4-Φ16
AST-UL-360/20-12	3000	360	3*73.339	1340*600*1860	900*500, 4-Φ18
AST-UL-480/20-12	4000	480	3*55.004	1400*600*2090	950*500, 4-Φ18
AST-UL-540/20-12	4500	540	3*48.892	1430*600*2200	1000*550, 4-Φ18
AST-UL-600/20-12	5000	600	3*44.033	1430*650*2400	1000*550, 4-Φ18

AST-UL 型, 35kV 系统, 三相, XL/XC=6, 匹配电容器电压: 38.1kV

电抗器型号	匹配电容器规格 (kvar)	电抗器容量 (kvar)	电感量 (mH)	外形尺寸 L*W*H (mm)	安装尺寸 (mm)
AST-UL-300/35-6	5000	300	3*55.447	1780*750*1920	1250*650, 4-Φ16
AST-UL-360/35-6	6000	360	3*46.206	1810*750*1990	1250*650, 4-Φ18
AST-UL-432/35-6	7200	432	3*38.152	1840*750*2120	1300*650, 4-Φ18
AST-UL-480/35-6	8000	480	3*34.655	1840*750*2240	1300*650, 4-Φ18
AST-UL-600/35-6	10000	600	3*27.723	1870*750*2360	1300*650, 4-Φ18

上表中的电抗外形尺寸仅作参考; 其他电压等级和电抗率的电抗可定制。

AST-UL 型, 35kV 系统, 三相, XL/XC=12%, 匹配电容器电压: 41.6kV

电抗器型号	匹配电容器规格 (kvar)	电抗器容量 (kvar)	电感量 (mH)	外形尺寸 L*W*H (mm)	安装尺寸 (mm)
AST-UL-600/35-12	5000	600	3*132.205	2080*750*2090	1450*650, 4-Φ18
AST-UL-720/35-12	6000	720	3*110.171	2140*750*2150	1500*650, 4-Φ20
AST-UL-864/35-12	7200	864	3*91.809	2170*800*2280	1500*700, 4-Φ20
AST-UL-960/35-12	8000	960	3*82.628	2170*800*2410	1500*700, 4-Φ20
AST-UL-1200/35-12	10000	1200	3*66.103	2200*750*2660	1500*650, 4-Φ20

上表中的电抗外形尺寸仅作参考; 其他电压等级和电抗率的电抗可定制。

